

ADAM TECH

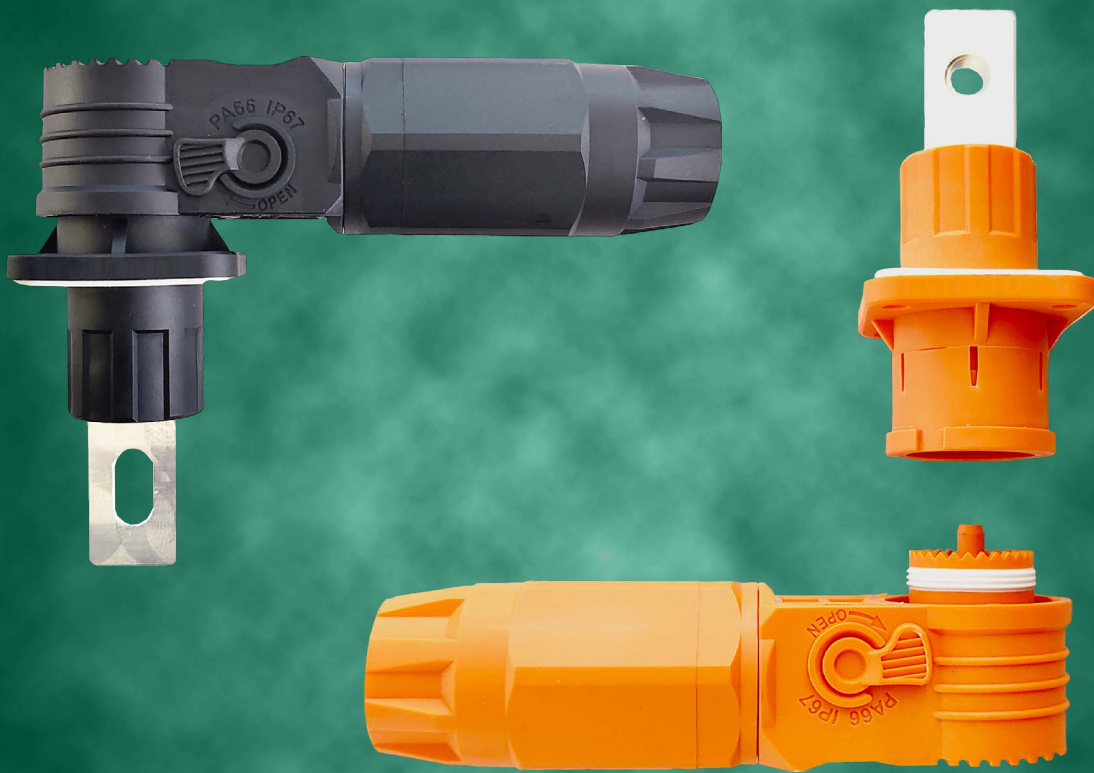

ENERGY STORAGE
CONNECTORS

Energy Storage Connectors

Adam Tech's ESF/ESM Series Energy Storage Connectors provide a critical link between battery modules. This link ensures safe and reliable connections in energy storage systems, such as electric vehicle charging, renewable energy devices, and both industrial and consumer energy storage. The series is composed of various mated pairs, offered in both orange and black. Various voltage ratings, current ratings, and wire gauges are supported, making this series compatible with a wide range of applications. Compatible dust covers are available, providing additional protection.

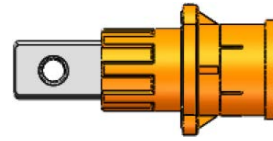

ESF Series

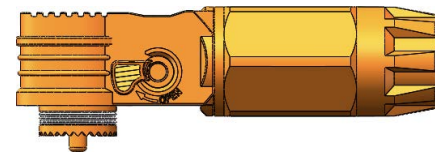

ESM Series

FEATURES AND BENEFITS:

- Providing reliable and efficient energy transfers
- Broad current range of 90A to 350A
- Voltage range of 1000VDC to 1500VDC
- Various wire gauge options
- Termination options: crimp, threaded hole, screw post, and busbar
- Orange and black housing
 - Mated pairs
- IP67 waterproof when mated
- UL 94V-0 flammability protection
 - PA66 materials
- RoHS & REACH compliant
- UL recognized 
- Compatible dust covers

MARKETS & APPLICATIONS:

- Energy storage systems
- Electric vehicles
- Renewable energy
 - Solar array
 - Wind energy
 - Hydropower
- Industrial
 - Process control
 - Automation
 - Heavy equipment
- Consumer electronics
- Data center
- Rail

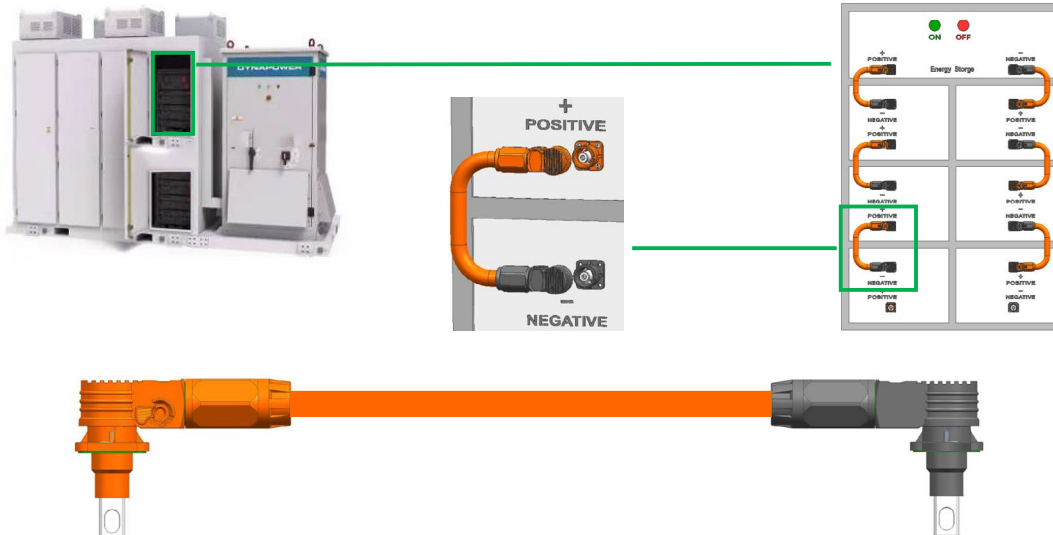

CUSTOM CABLE ASSEMBLIES AVAILABLE UPON REQUEST. CONTACT US AT INFO@ADAM-TECH.COM.

ESF-0XXA02-XXXXXX
ESF-1XXA02-XXXXXX
Energy Storage Connectors
FEMALE

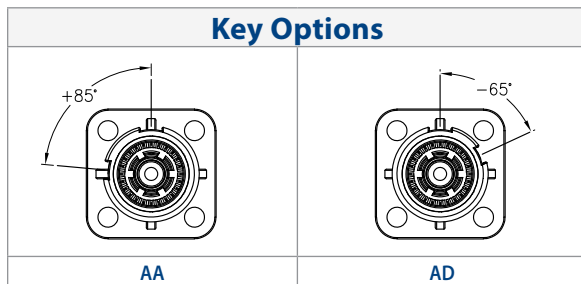
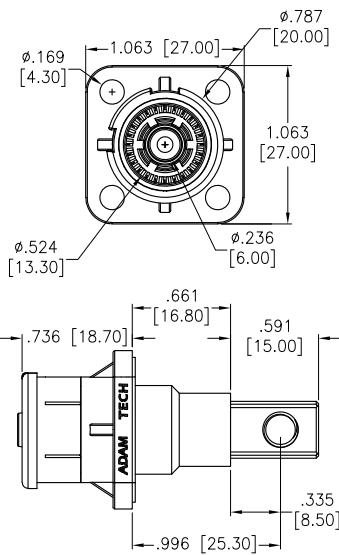
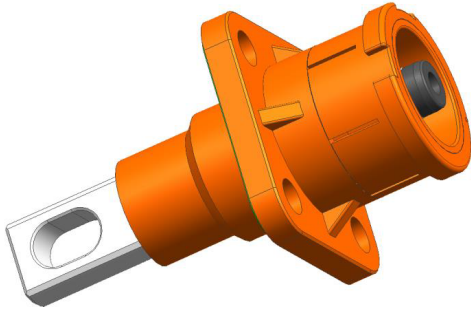

*Please contact info@adam-tech.com for additional key options.

Product Number

ESF – **XXX** **A02** – **XX** **X** **XXX**
A **B** **C** **D** **E** **F**

A: Series
B: Current Rating
C: Version
D: Key Options (see bottom of page)
E: Housing Color
F: Terminal Type

| | |
|-----|----------|
| 090 | 90 amps |
| 120 | 120 amps |

| | |
|---|--------|
| O | Orange |
| B | Black |

Terminal Type Chart

| Code | Terminal | Specification | Universal Model |
|------|--|---|-----------------|
| 010 | Threaded Hole | M6x1.0 Thread | 90A or 120A |
| 020 | Busbar (Threaded Hole) | M5x0.8 Thread | |
| 030 | Screw Post | M6x1.25 Thread | |
| 040 | Busbar (Through Hole) | ϕ 5.20 Hole | 120A |
| 051 | Crimp Adam Tech PN: (ESF-120A02-XX051) | AWG American Wire Gauge Wire Standard: 4 AWG Strand Outer Diameter: ϕ 6.47 Max O.D. (Outside Diameter): ϕ 9.50 Max International Wire Gauge Wire Standard: 25mm ² Strand Outer Diameter: ϕ 7.20 Max O.D. (Outside Diameter): ϕ 9.80 Max | |
| 052 | Crimp Adam Tech PN: (ESF-090A02-XX052) | AWG American Wire Gauge Wire Standard: 6 AWG Strand Outer Diameter: ϕ 5.20 Max O.D. (Outside Diameter): ϕ 8.50 Max International Wire Gauge Wire Standard: 16mm ² Strand Outer Diameter: ϕ 5.80 Max O.D. (Outside Diameter): ϕ 8.00 Max | 090A |

Product Parameters

| No. | Name | Parameters |
|-----|-------------------------|---|
| 1 | Rated Current | 90A MAX for 6 AWG and 16mm ² 120A MAX for 4 AWG and 25mm ² |
| 2 | Rated Voltage | 1000V DC |
| 3 | Withstand Voltage | 3800V DC |
| 4 | Contact Resistance | \leq 0.5m Ω MAX |
| 5 | Environment Temperature | -40 $^{\circ}$ ~+125 $^{\circ}$ |
| 6 | Waterproofing Grade | IP67 (mating state) |
| 7 | Salt Spray Test | 48H |
| 8 | Mating Life | \geq 500times |
| 9 | Fire Rating | UL 94-V0 |

Click [here](#) to view datasheet.

ESM-0XXA02-XXX
ESM-1XXA02-XXX
Energy Storage Connectors
MALE

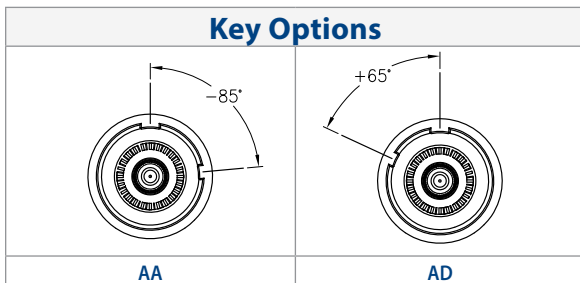
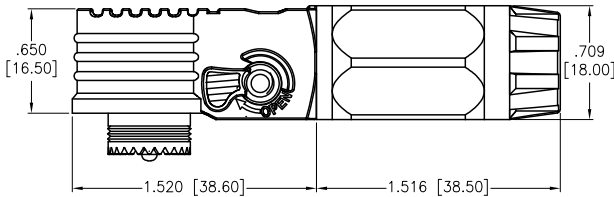
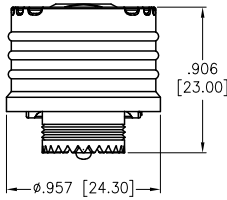
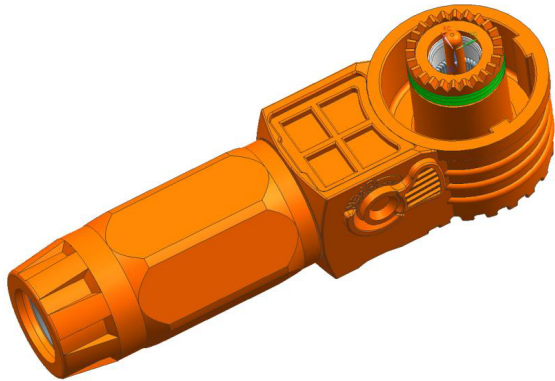

*Please contact info@adam-tech.com for additional key options.

Product Number

$\frac{ESM}{A} - \frac{XXX}{B} \frac{A02}{C} - \frac{XX}{D} \frac{X}{E}$

- A: Series
- B: Current Rating
- C: Version
- D: Key Options (see bottom of page)
- E: Housing Color

| | |
|-----|----------|
| 090 | 90 amps |
| 120 | 120 amps |

| | |
|---|--------|
| O | Orange |
| B | Black |

Suitable Wire Gauge

| Specification | | Universal Model |
|----------------------------|------------------------------------|-----------------|
| AWG American Wire Gauge | Wire Standard: 4 AWG | 120A |
| | Strand Outer Diameter: ø6.47 Max | |
| | O.D. (Outside Diameter): ø9.50 Max | |
| International Wire Gauge | Wire Standard: 25mm ² | 090A |
| | Strand Outer Diameter: ø7.20 Max | |
| | O.D. (Outside Diameter): ø9.80 Max | |
| AWG American Wire Gauge | Wire Standard: 6 AWG | 090A |
| | Strand Outer Diameter: ø5.20 Max | |
| | O.D. (Outside Diameter): ø8.50 Max | |
| International Wire Gauge | Wire Standard: 16mm ² | 090A |
| | Strand Outer Diameter: ø5.80 Max | |
| | O.D. (Outside Diameter): ø8.00 Max | |

Product Parameters

| No. | Name | Parameters |
|-----|-------------------------|--|
| 1 | Rated Current | 090A MAX for 6 AWG and 16mm ² 120A MAX for 4 AWG and 25mm ² |
| 2 | Rated Voltage | 1000V DC |
| 3 | Withstand Voltage | 3800V DC |
| 4 | Contact Resistance | ≤0.5mΩ MAX |
| 5 | Environment Temperature | -40°~+125° |
| 6 | Waterproofing Grade | IP67 (mating state) |
| 7 | Salt Spray Test | 48H |
| 8 | Mating Life | ≥500times |
| 9 | Fire Rating | UL 94-V0 |

Click [here](#) to view datasheet.

ESF-2XXA02-XXXXXX
Energy Storage Connector
FEMALE

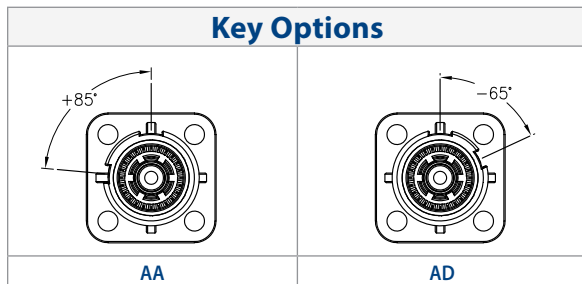
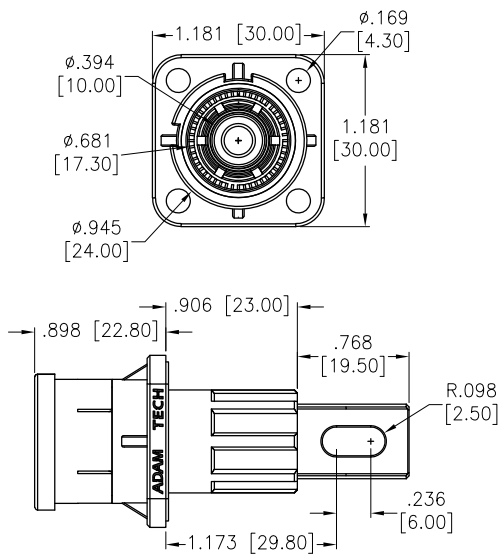
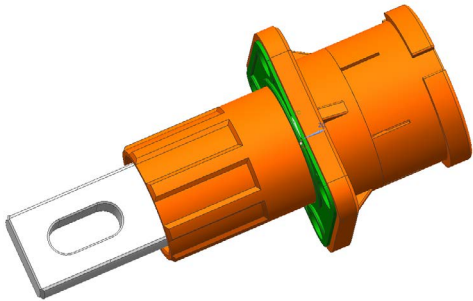

*Please contact info@adam-tech.com for additional key options.

Product Number

ESF - $\frac{2XX}{A}$ $\frac{A02}{C}$ - $\frac{XX}{D}$ $\frac{X}{E}$ $\frac{XXX}{F}$

A: Series
B: Current Rating
C: Version
D: Key Options (see bottom of page)
E: Housing Color
F: Terminal Type

| | |
|-----|----------|
| 200 | 200 amps |
| 250 | 250 amps |

| | |
|---|--------|
| O | Orange |
| B | Black |

Terminal Type Chart

| Code | Terminal | Specification | Universal Model |
|------|--|--|-----------------|
| 010 | Threaded Hole | M6x1.0 Thread | 200A or 250A |
| 020 | Busbar (Threaded Hole) | M8x1.25 Thread | |
| 030 | Screw Post | M6x1.0 Thread | |
| 040 | Busbar (Through Hole) | ø5.0 Hole | 200A |
| 051 | Crimp Adam Tech PN: (ESF-200A02-XX051) | AWG American Wire Gauge Wire Standard: 1/0 AWG Strand Outer Diameter: ø10.3 Max O.D. (Outside Diameter): ø14.2 Max | |
| | | International Wire Gauge Wire Standard: 50mm ² Strand Outer Diameter: ø10.2 Max O.D. (Outside Diameter): ø13.5 Max | |
| 052 | Crimp Adam Tech PN: (ESF-250A02-XX052) | AWG American Wire Gauge Wire Standard: 2/0 AWG Strand Outer Diameter: ø11.6 Max O.D. (Outside Diameter): ø15.1 Max | 250A |
| | | International Wire Gauge Wire Standard: 70mm ² Strand Outer Diameter: ø12.2 Max O.D. (Outside Diameter): ø15.5 Max | |

Product Parameters

| No. | Name | Parameters |
|-----|-------------------------|--|
| 1 | Rated Current | 200A MAX for 1/0 AWG and 50mm ² 250A MAX for 2/0 AWG and 70mm ² |
| 2 | Rated Voltage | 1500V DC |
| 3 | Withstand Voltage | 6800V DC |
| 4 | Contact Resistance | ≤0.5mΩ MAX |
| 5 | Environment Temperature | -40°~+125° |
| 6 | Waterproofing Grade | IP67 (mating state) |
| 7 | Salt Spray Test | 48H |
| 8 | Mating Life | ≥500times |
| 9 | Fire Rating | UL 94-V0 |

Click [here](#) to view datasheet.

ESM-2XXA02-XXX
Energy Storage Connector
MALE

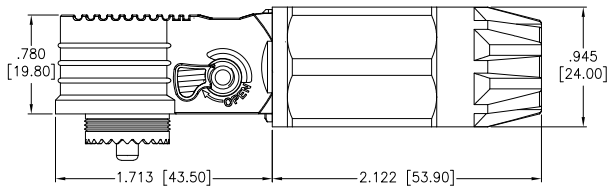
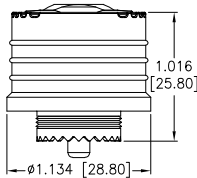

Key Options

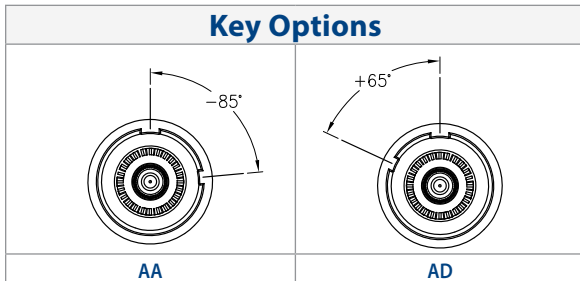

*Please contact info@adam-tech.com for additional key options.

Product Number

$\frac{ESM}{A} - \frac{2XX}{B} \quad \frac{A02}{C} - \frac{XX}{D} \quad \frac{X}{E}$

A: Series
B: Current Rating
C: Version
D: Key Options (see bottom of page)
E: Housing Color

| | |
|------------|----------|
| 200 | 200 amps |
| 250 | 250 amps |

| | |
|----------|--------|
| O | Orange |
| B | Black |

Suitable Wire Gauge

| Specification | | Universal Model |
|----------------------------|--|-----------------|
| AWG American Wire Gauge | Wire Standard: 1/0 AWG | 200A |
| | Strand Outer Diameter: ϕ 10.3 Max | |
| | O.D. (Outside Diameter): ϕ 14.2 Max | |
| International Wire Gauge | Wire Standard: 50mm ² | 250A |
| | Strand Outer Diameter: ϕ 10.2 Max | |
| | O.D. (Outside Diameter): ϕ 13.5 Max | |
| AWG American Wire Gauge | Wire Standard: 2/0 AWG | 250A |
| | Strand Outer Diameter: ϕ 11.6 Max | |
| | O.D. (Outside Diameter): ϕ 15.1 Max | |
| International Wire Gauge | Wire Standard: 70mm ² | 250A |
| | Strand Outer Diameter: ϕ 12.2 Max | |
| | O.D. (Outside Diameter): ϕ 15.5 Max | |

Product Parameters

| No. | Name | Parameters |
|-----|-------------------------|--|
| 1 | Rated Current | 200A MAX for 1/0 AWG and 50mm ² 250A MAX for 2/0 AWG and 70mm ² |
| 2 | Rated Voltage | 1500V DC |
| 3 | Withstand Voltage | 6800V DC |
| 4 | Contact Resistance | \leq 0.5m Ω MAX |
| 5 | Environment Temperature | -40 $^{\circ}$ ~+125 $^{\circ}$ |
| 6 | Waterproofing Grade | IP67 (mating state) |
| 7 | Salt Spray Test | 48H |
| 8 | Mating Life | \geq 500times |
| 9 | Fire Rating | UL 94-V0 |

Click [here](#) to view datasheet.

ESF-3XXA02-XXXXXX
Energy Storage Connector
FEMALE

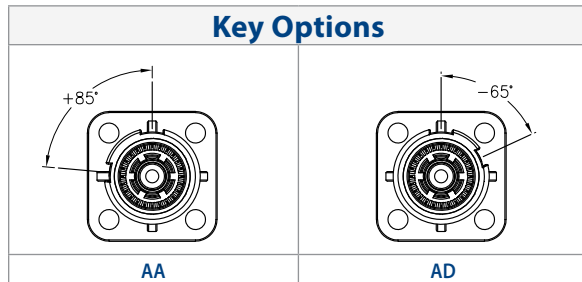
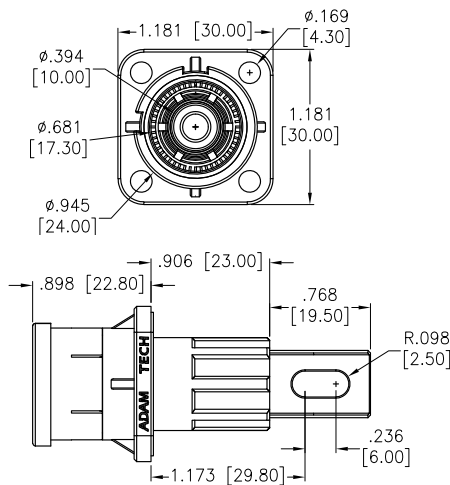
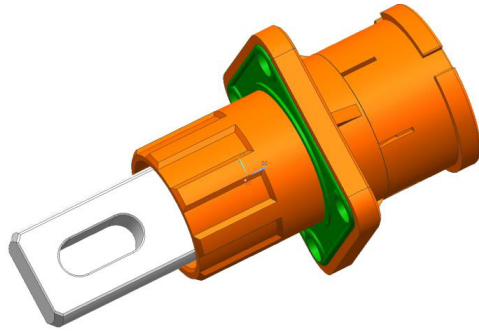

*Please contact info@adam-tech.com for additional key options.

Product Number

$\frac{ESF}{A} - \frac{3XX}{B} \frac{A02}{C} - \frac{XX}{D} \frac{X}{E} \frac{XXX}{F}$

A: Series
B: Current Rating
C: Version
D: Key Options (see bottom of page)
E: Housing Color
F: Terminal Type

| | |
|-----|----------|
| 300 | 300 amps |
| 350 | 350 amps |

| | |
|---|--------|
| O | Orange |
| B | Black |

Terminal Type Chart

| Code | Terminal | Specification | Universal Model |
|------|--|--|-----------------|
| 010 | Threaded Hole | M6x1.0 Thread | 300A or 350A |
| 020 | Busbar (Threaded Hole) | M8x1.25 Thread | |
| 030 | Screw Post | M6x1.0 Thread | |
| 040 | Busbar (Through Hole) | ø6.0 Hole | 350A |
| 051 | Crimp Adam Tech PN: (ESF-350A02-XX051) | AWG American Wire Gauge Wire Standard: 4/0 AWG Strand Outer Diameter: ø14.7 Max O.D. (Outside Diameter): ø18.5 Max | |
| 052 | Crimp Adam Tech PN: (ESF-300A02-XX052) | International Wire Gauge Wire Standard: 95mm ² Strand Outer Diameter: ø14.2 Max O.D. (Outside Diameter): ø17.6 Max | 300A |

Product Parameters

| No. | Name | Parameters |
|-----|-------------------------|--|
| 1 | Rated Current | 300A MAX for 95mm ² 350A MAX for 4/0 AWG |
| 2 | Rated Voltage | 1500V DC |
| 3 | Withstand Voltage | 6800V DC |
| 4 | Contact Resistance | ≤0.5mΩ MAX |
| 5 | Environment Temperature | -40°~+125° |
| 6 | Waterproofing Grade | IP67 (mating state) |
| 7 | Salt Spray Test | 48H |
| 8 | Mating Life | ≥500times |
| 9 | Fire Rating | UL 94-V0 |

Click [here](#) to view datasheet.

ESM-3XXA02-XXX
Energy Storage Connector
MALE

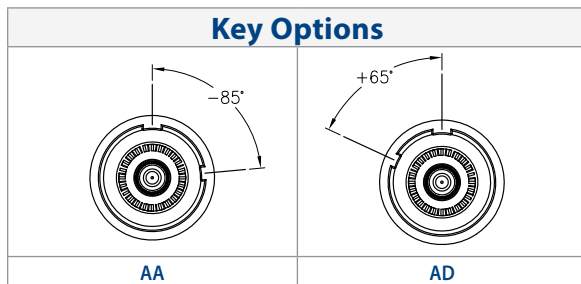
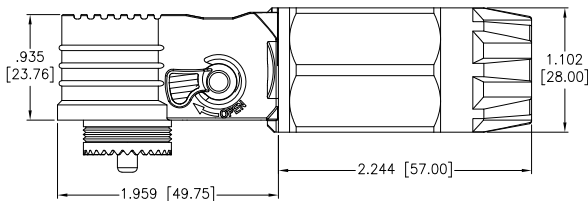
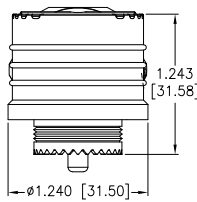
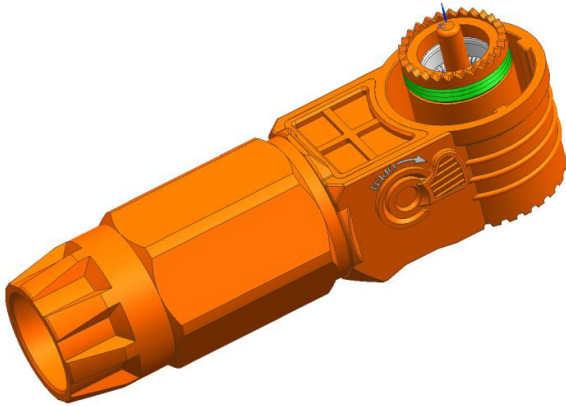

*Please contact info@adam-tech.com for additional key options.

Product Number

$\frac{ESM}{A} - \frac{3XX}{B} \quad \frac{A02}{C} - \frac{XX}{D} \quad \frac{X}{E}$

A: Series
B: Current Rating
C: Version
D: Key Options
E: Housing Color

| | |
|-----|----------|
| 300 | 300 amps |
| 350 | 350 amps |

| | |
|---|--------|
| O | Orange |
| B | Black |

Suitable Wire Gauge

| Specification | | Universal Model |
|----------------------------|--|-----------------|
| AWG American Wire Gauge | Wire Standard: 4/0 AWG | 350A |
| | Strand Outer Diameter: ϕ 14.7 Max | |
| | O.D. (Outside Diameter): ϕ 18.5 Max | |
| International Wire Gauge | Wire Standard: 95mm ² | 300A |
| | Strand Outer Diameter: ϕ 14.2 Max | |
| | O.D. (Outside Diameter): ϕ 17.6 Max | |

Product Parameters

| No. | Name | Parameters |
|-----|-------------------------|--|
| 1 | Rated Current | 300A MAX for 95mm ² 350A MAX for 4/0 AWG |
| 2 | Rated Voltage | 1500V DC |
| 3 | Withstand Voltage | 6800V DC |
| 4 | Contact Resistance | \leq 0.5m Ω MAX |
| 5 | Environment Temperature | -40 $^{\circ}$ ~+125 $^{\circ}$ |
| 6 | Waterproofing Grade | IP67 (mating state) |
| 7 | Salt Spray Test | 48H |
| 8 | Mating Life | \geq 500times |
| 9 | Fire Rating | UL 94-V0 |

Click [here](#) to view datasheet.

Safety Instructions

The assembly instructions and assembly procedure instructions are an important part and prerequisite for UL certification.

The product can be assembled or installed by personnel who have electrical skills or have been instructed in this respect in accordance with applicable safety regulation.

If you fail to comply with the above and below warnings, Adam Tech will not assume any responsibility.

Only the components and tools specified by our company can be used. When assembling by yourself, do not deviate from the preparation and assembly instructions described in this manual, otherwise our company cannot guarantee the use safety or performance of the product to meet the official technical parameters. Do not modify the product in any way.

Connectors that are not manufactured by our company but can be plugged into our components, as well as connectors that other manufacturers claim to be compatible with our company, do not meet the long-term stable and safe electrical connection requirements. For safety reasons, the above products shall not be used together with our components. Therefore, our company will not bear any responsibility for any loss caused by the connection of such connectors (that is without our approval) with our components.

IEC-60417-6042 Caution: Risk Of Electric Shock

Work in a de-energized state. Follow the five safety rules, when working on electrical installations. After the respective electrical installations have been identified, the following five essential requirements shall be undertaken in the specified order unless there are essential reasons for doing otherwise:

- Disconnect completely
- Secure against re-connection
- Verify absence of operating voltage
- Carry out earthing and short-circuiting
- Provide protection against adjacent live parts

Any person engaged in this work activity shall be electrically skilled or instructed, or shall be supervised by such a person. Source: EN 50110-1:2013. Protection against electric shock shall be checked in the end-use applications.

IEC-60417-6070 Do Not Disconnect Under Load

Do not disconnect or plug connectors under load. The source switch can be closed to make it in no-load state for separation and connection.

ISO 7000-0434B Matters Needing Attention

Before each use of the connector, it is necessary to check in advance whether there are defects on the outside (especially the insulation layer). If there are safety concerns, you must consult professional personnel or replace the connector. The waterproof function of the connector can refer to the IP protection grade of relevant products. However, they are not suitable for long-term underwater use. Do not put the connector directly in the environment without any protection for a long time. The rated voltage is the maximum voltage and is only suitable for cable connectors. The final rated voltage of the cable harness depends on the lowest and maximum rated voltage of the component and the relevant standards for its evaluation and certification. Connectors that are not plugged in must be protected from moisture and dust with sealing covers. Contaminated male and female connectors should not be plugged in. The components shall not be subjected to permanent mechanical tensile loads. According to local electrical codes and standards, cables shall be fixed with ties. Always observe the prescribed installation position. Confirm that the correct coding is used. Parts and packaging materials are not toys; there is a risk of suffocation if small parts are swallowed. The packaging materials may cause suffocation. The product must be used in strict accordance with the specifications given in the technical parameters (such as providing sufficient back ventilation to ensure that the connector is in the normal operating temperature range). It is strictly forbidden to pollute the product with any grease.

Note On Storage

We recommend that you store connector components at a temperature between -30°C and +60°C and with a relative humidity of less than 70%.

The components must not be exposed to moisture due to direct rainfall, condensation, etc. Ensure that the individual components do not come into contact with acids, alkalis, gases, acetone, or any other chemical substances that could impact the materials used.

If these conditions are met, the components can be stored for a maximum period of up to two years from the date of manufacture.

Scope Of Application

The expected application of energy storage connectors and corresponding tools is the basic requirement for safe application and technically correct assembly of connectors. The energy storage connector shall only be used for power energy storage and large current transmission applications. It is only allowed to be applied within the technical specifications described in item 1. Only qualified and experienced personnel are allowed to use the tools issued by our company for assembly and application, and the assembly instructions, installation standards and national and international safety regulations should be considered.

Examples Of Unintended Use

- Failure to observe safety regulations
- Failure to observe the safety instructions of these assembly instructions
- Use connectors not manufactured or approved by our company

Dangers Of Unintended Use

- Injury to persons as a result of electric shock
- Blindness and or fire hazard due to arcing

Note

The wearing of suitable personal protective equipment (PPE) is in the responsibility of the user.

Adapter Cable

It is recommended that the cable specification and size should be selected according to the size indicated in the engineering drawing.

| Rated Current | Wire Gauge | Conductor Outer Diameter mm | Insulation Outer Diameter mm | Stripping Length mm |
|---------------|-------------------|-----------------------------|------------------------------|---------------------|
| 90A | 6 AWG | 5.0 ±0.2 | 8.5 ±0.3 | 14.5 ±0.5 |
| | 16mm ² | 5.6 ±0.2 | 8.0 ±0.3 | |
| 120A | 4 AWG | 6.4 ±0.2 | 9.8 ±0.3 | 14.5 ±0.5 |
| | 25mm ² | 6.9 ±0.2 | 9.5 ±0.3 | |
| 200A | 1/0 Awg | 10.3 ±0.2 | 14.2 ±0.3 | 18.0 ±1 |
| | 50mm ² | 10.2 ±0.2 | 13.5 ±0.3 | |
| 250A | 2/0 Awg | 11.6 ±0.2 | 15.1 ±0.3 | 18.0 ±1 |
| | 70mm ² | 12.2 ±0.2 | 15.5 ±0.3 | |
| 300A | 95mm ² | 14.2 ±0.2 | 17.6 ±0.3 | 20.0 ±1 |
| 350A | 4/0 Awg | 14.7 ±0.2 | 18.5 ±0.3 | 20.0 ±1 |

Assembly Process

Tools Required:

- Please use special wire cutters and wire strippers
- Special wire crimping machine
- 18mm open-end wrench

Assembly Process

Male Head

Unscrew the nut and waterproof ring.

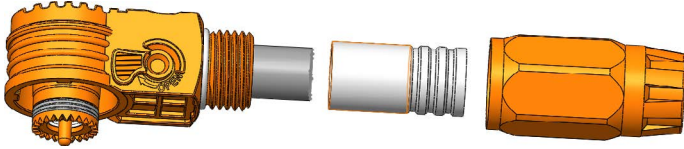

Strip the insulation layer off the cable.

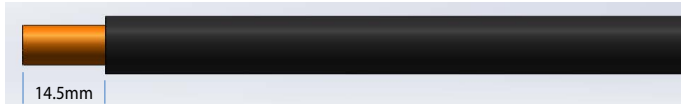

Attach nut and waterproof ring to cable.

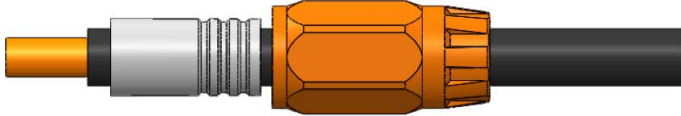

Insert the conductor into the cable slot.

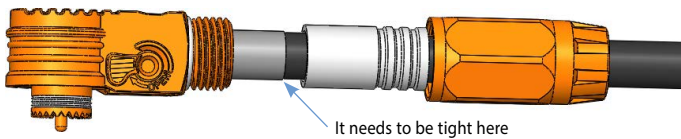

Press the conductor part of the cable into the front terminal, leaving a 1.0-1.5mm flare at the end of the terminal.

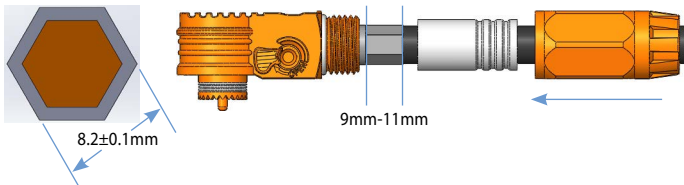

Push the waterproof ring and nut clockwise to the plug and tighten (torque: $\leq 0.5N\cdot m$).

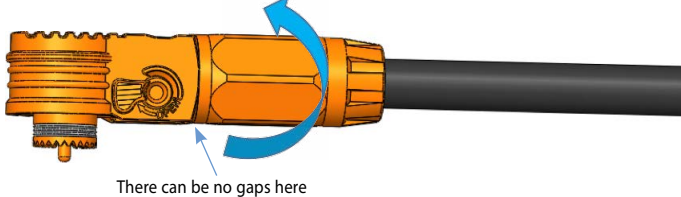

Female Head

Products with the last three digits of the socket number being 010, 020, 030, or 040 are universal hard-connected copper bars that can accommodate a maximum current of 350A.

Our company has completed the assembly before leaving the factory, and customers can install and use them directly.

For more detailed product information, please refer to the engineering drawing.

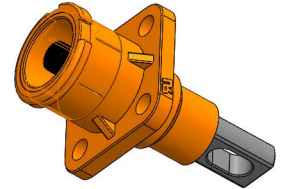

Strip the insulation layer off the cable.

051/052 terminal stripping length $14.5\pm 0.5mm$.

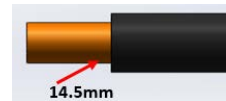

Insert the stripped cable into the male terminal until the insulation layer touches the terminal, and use a crimping machine to perform hexagonal crimping.



Insert the crimped terminal into the socket until you hear a "click" sound. Pull the cable back slightly to confirm that the terminal is firmly in place.

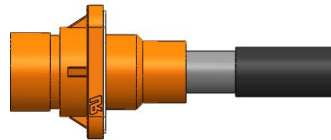

Use heat shrink tubing to completely wrap the exposed terminal, and wrap the cable about 30mm, and use a hot air gun to shrink the heat shrink tubing.

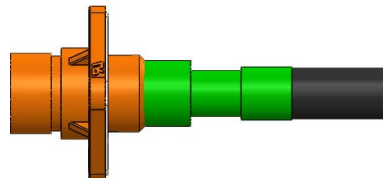

CUSTOM CABLE ASSEMBLIES AVAILABLE UPON REQUEST. CONTACT US AT INFO@ADAM-TECH.COM.

Assembly Process

Socket Mounting Method

Use M4 combination screws to lock the socket connector on the panel with waterproof pads (recommended torque is 0.80-1N.m).

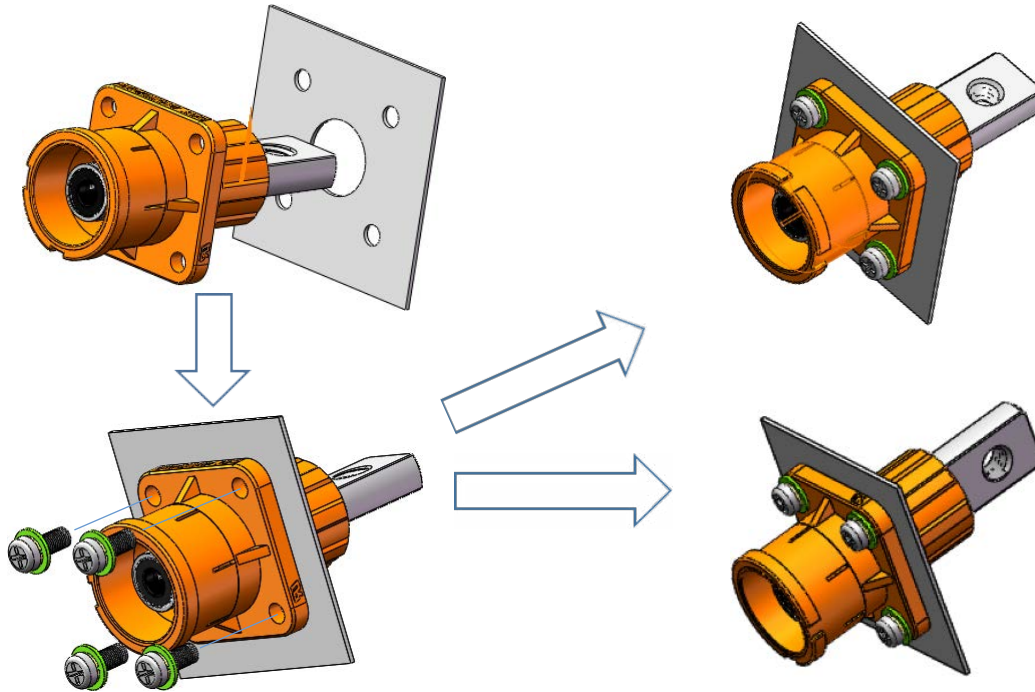

Note: Please use recommended screw torque.

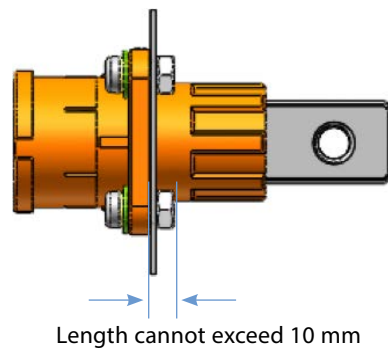
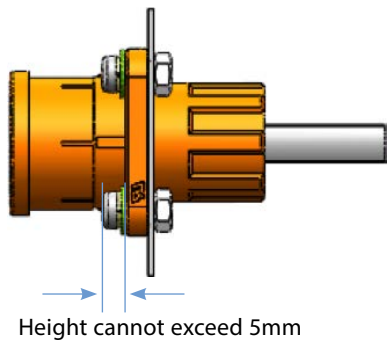

Note: If there are special requirements, the fasteners need to be added with an insulating layer.

Assembly Process

Male and Female Connector Mating

Manually mate the plug connector to the corresponding socket connector according to the customer's installation angle until a "click" sound is heard.

Connect receptacle terminal with customer's busbar contact.

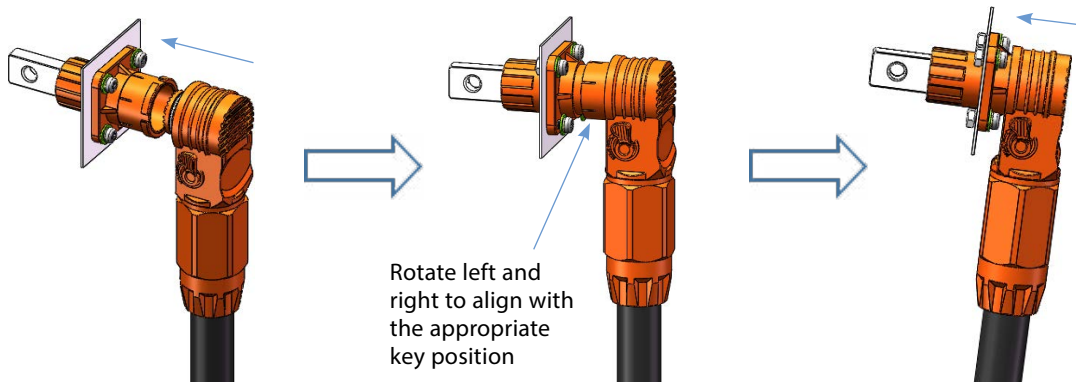

Connecting to Busbar

Use bolt, spring washer and flat washer.

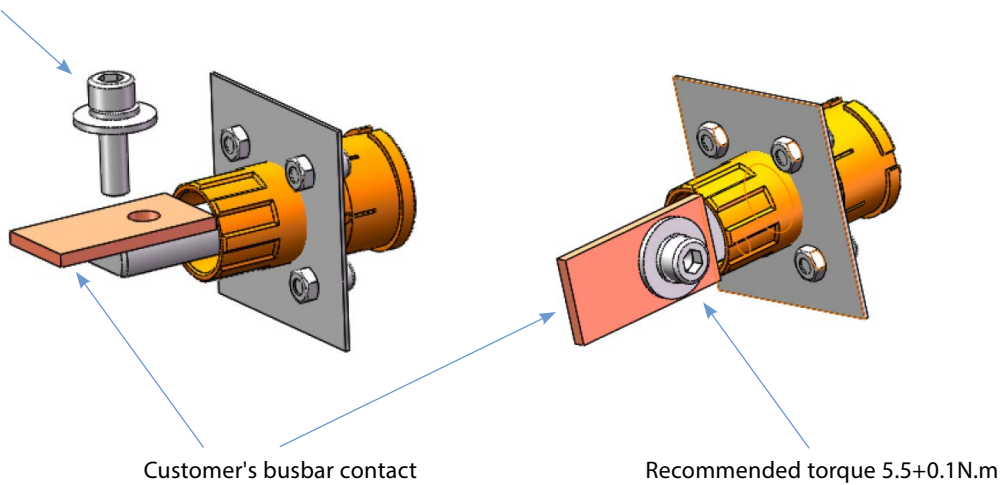

Note: Please use the recommended torque and verify it if modified.



To contact us, scan the QR
code to reach our website
inquiry form.

adam-tech.com

Created: Oct-2024
Last Revised: Jan-2025

CONFIDENTIAL AND PROPRIETARY

© Adam Tech. All rights reserved. This document contains confidential and proprietary information belonging to Adam Tech. It is provided solely for design and reference purposes by authorized parties. Any reproduction, distribution, display, or disclosure to third parties, in whole or in part, without the prior written consent of Adam Tech, is strictly prohibited. Adam Tech retains all rights, including copyright, trademark, trade secret, and all other intellectual property rights worldwide.