

Rev	AWO #	Description	Date	Appr
-		RELEASED	9/10/13	

APPROVED: _____
 DATE: _____ TITLE: _____

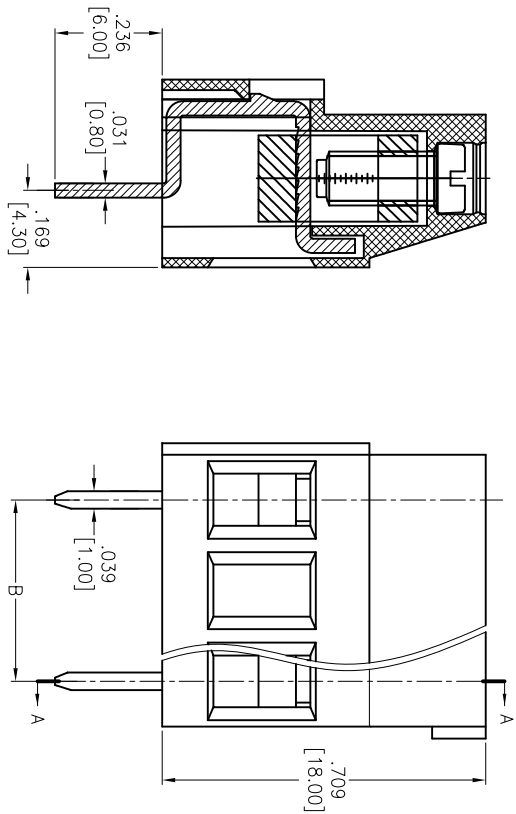
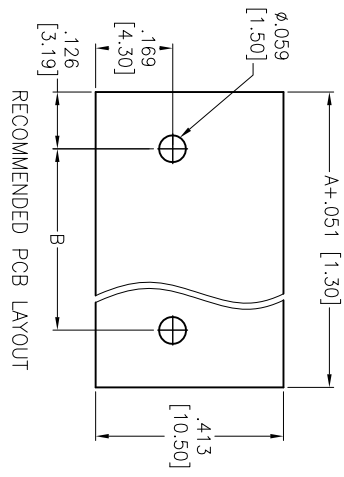
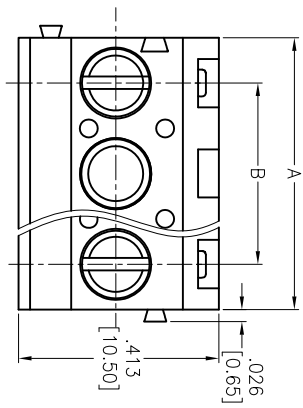

SPECIFICATIONS:

- Material: Insulator: PA66, rated UL 94V-0
- Insulator color: Green
- Screw: Steel, M3.0/Zinc plated
- Cage: Brass, Tin plated
- Pin Header: Brass, Tin plated
- Electrical:
 - Voltage rated: 300 VAC
 - Current rated: 16 Amps
 - Contact resistance: 20 mΩ
 - Insulation resistance: 500 MΩ @ 500 VDC
 - Withstanding voltage: 2000V AC/1 Min
- Mechanical:
 - Solid wire: 26-12AWG 2.5mm²
 - Torque (Lb-in): 0.5Nm (4.5lb-in)
 - Strip length: 6-7mm
 - Temperature Rating: Operating temperature: -40°C to +105°C
- Environmental: Lead free, RoHS compliant.

Positions: 02 thru 24
 A = .400 [10.16] x No. of Spaces +.200 [5.08]
 B = .400 [10.16] x No. of Spaces

UNLESS OTHERWISE SPECIFIED
 ALL DIMENSIONS ARE INCHES [MM]
 TOLERANCES: EXCEPT AS NOTED

INCHES	HOLES
.X ± .10	ØX ± .10
.XX ± .020	ØXX ± .015
.XXX ± .015	ØXXX ± .010

ADAM TECH
 909 Railway Avenue, Union, NJ 07083
 Phone: 908-687-5000 Fax: 908-687-5710

EURO BLOCK, .400 [10.16] PITCH

APPROVALS	DATE	TITLE	SIZE	PART NO.	REV.
DRAWN AY	9/10/13	EURO BLOCK, .400 [10.16] PITCH	X	EB147A-XX-J	-
CHECKED AH	9/10/13				
APPROVED					

