

APPROVED: _____

DATE: _____ TITLE: _____

Rev	AWO #	Description	Date	Appr
-		RELEASED	12/18/23	
A		UPDATE DRAWING	7/26/24	LH/RC
B		UPDATE DRAWING	8/6/24	LH/RC
C		ADDED SPEC.	8/21/24	LH/RL

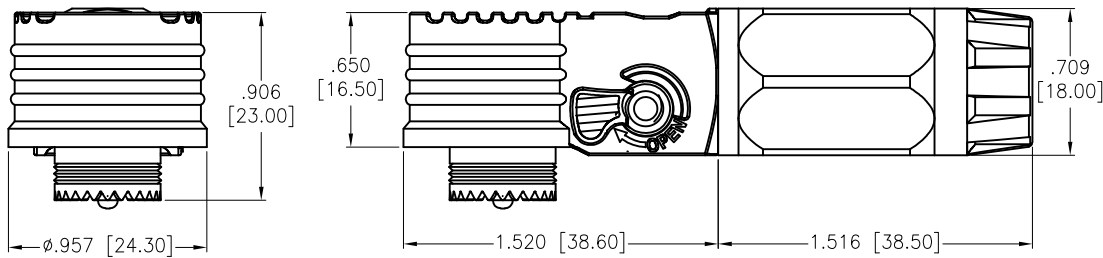

ESM-XXXXA02-XXX

Universal model: 120A, 090A

Key Options

Housing Color:
O=Orange
B=Black

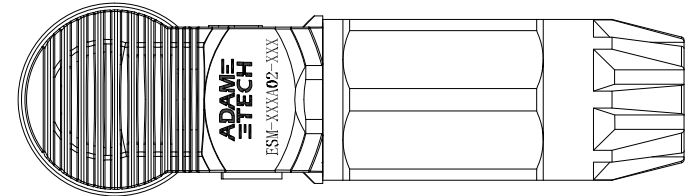

laser marking
Orange is positive: (+)
black is negative: (-)

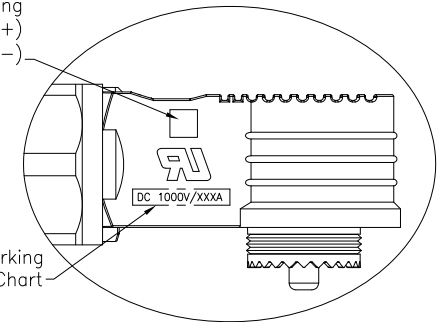

laser marking
See Chart

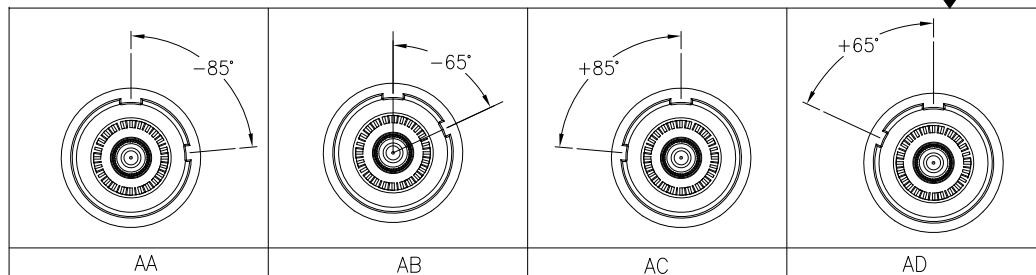

Suitable wire gauge

Specification		Universal model
AWG American wire gauge	Wire standard: 4 AWG	120A
	Strand outer diameter: ø6.47 Max	
	O.D (Outside Diameter): ø9.50 Max	
International Wire Gauge	Wire standard: 25mm ²	090A
	Strand outer diameter: ø7.20 Max	
	O.D (Outside Diameter): ø9.80 Max	
AWG American wire gauge	Wire standard: 6 AWG	090A
	Strand outer diameter: ø5.20 Max	
	O.D (Outside Diameter): ø8.50 Max	
International Wire Gauge	Wire standard: 16mm ²	090A
	Strand outer diameter: ø5.80 Max	
	O.D (Outside Diameter): ø8.00 Max	

SPECIFICATIONS:

Connector:
Housing: PA66, Glass reinforced, rated UL 94V-0
Housing color: Orange/Black
Cap: PA66, Glass reinforced, rated UL 94V-0
Top: PA66, Glass reinforced, rated UL 94V-0
Waterproof ring: Silicone
Contact: Pure Red Copper, Silver plated Surface
Spring: SUS301
Electrical:

Voltage rating: 1000V DC
Current rating: 90A/120A
Contact resistance: 0.5 mohms max
Insulation resistance: 1,000 Mohms min
Dielectric withstanding voltage: 3,800V DC

Mechanical:
Durability: 500 cycles
Overvoltage Category/Pollution Degree: CATIII/3
Temperature Rating: -40°C to +125°C

Environmental:
Waterproof: IP67 (Mating)
Lead free, RoHS compliant



UNLESS OTHERWISE SPECIFIED ALL DIMENSIONS ARE INCHES [MM]. TOLERANCES: EXCEPT AS NOTED

INCHES		HOLES	
.X	± .10	ø.X	±.10
.XX	± .020	ø.XX	±.015
.XXX	± .015	ø.XXX	±.010

DRAWN	WX	12/18/23
CHECKED	CK	12/18/23
APPROVED		

THIS DRAWING CONTAINS INFORMATION THAT IS PROPRIETARY AND SHOULD NOT BE USED WITHOUT PRIOR WRITTEN PERMISSION FROM ADAM TECH



909 Rahway Avenue,
Union, NJ 07083
Phone: 908-687-5000
Fax: 908-687-5710

TITLE		SIZE	PART NO.	REV.
ENERGY STORAGE CONNECTOR, MALE		X	ESM-XXXXA02-XXX	C
REF:	S00005C	SCALE:	NTS	SHEET 1 OF 3

APPROVED: _____

DATE: _____ TITLE: _____

Rev	AWO #	Description	Date	Appr
SEE SHT 1 OF 3 FOR REVISION				

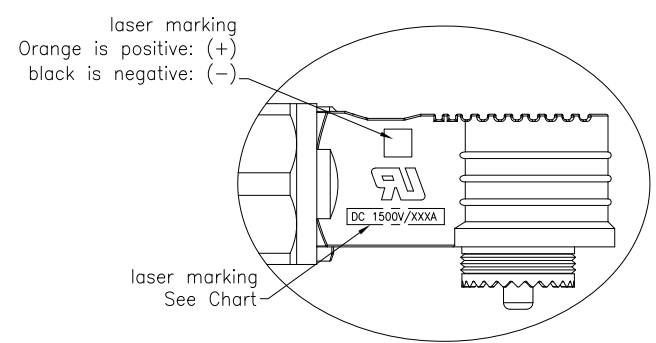
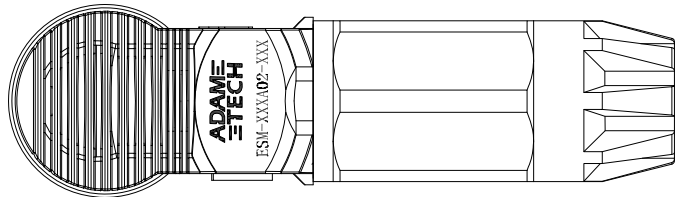
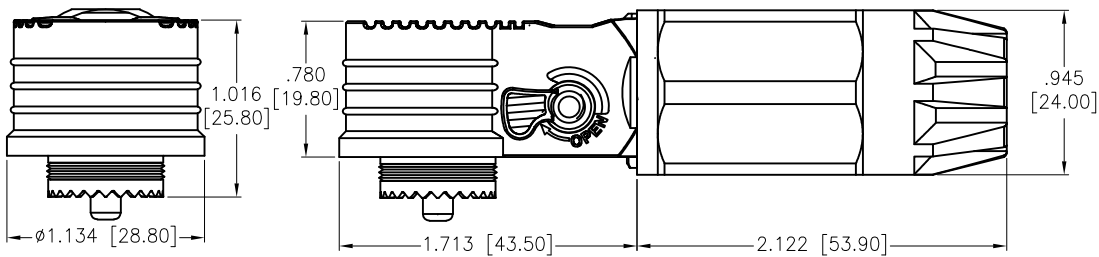

ESM-XXXXA02-XXX
 Universal model: 200A, 250A
 KEY Options
 Housing Color:
 O=Orange
 B=Black

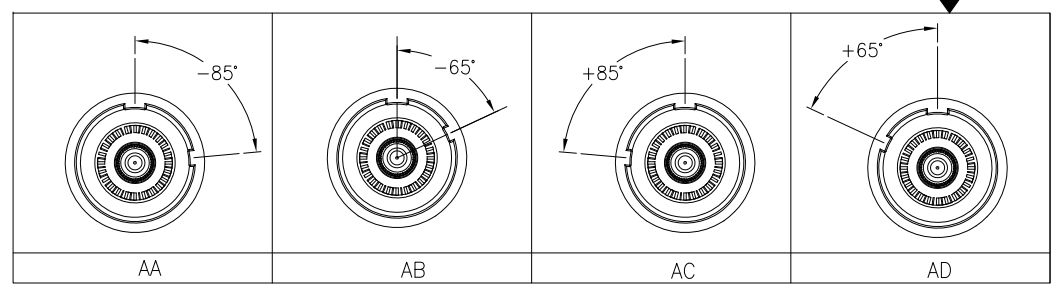

Suitable wire gauge

Specification		Universal model
International Wire Gauge	Wire standard: 70mm ²	250A
	Strand outer diameter: ϕ 12.2 Max	
	O.D (Outside Diameter): ϕ 15.5 Max	
AWG American wire gauge	Wire standard: 1/0 AWG	200A
	Strand outer diameter: ϕ 10.3 Max	
	O.D (Outside Diameter): ϕ 14.2 Max	
International Wire Gauge	Wire standard: 50mm ²	200A
	Strand outer diameter: ϕ 10.2 Max	
	O.D (Outside Diameter): ϕ 13.5 Max	

SPECIFICATIONS:

Connector:
 Housing: PA66, Glass reinforced, rated UL 94V-0
 Housing color: Orange/Black
 Cap: PA66, Glass reinforced, rated UL 94V-0
 Top: PA66, Glass reinforced, rated UL 94V-0
 Waterproof ring: Silicone
 Contact: Pure Red Copper, Silver plated Surface
 Spring: SUS301
 Electrical:
 Voltage rating: 1500V DC
 Current rating: 200A/250A
 Contact resistance: 0.5 mohms max
 Insulation resistance: 1,000 Mohms min
 Dielectric withstanding voltage: 6,800V DC
 Mechanical:
 Durability: 500 cycles
 Overvoltage Category/Pollution Degree: CATIII/3
 Temperature Rating: -40°C to +125°C
 Environmental:
 Waterproof: IP67 (Mating)
 Lead free, RoHS compliant



UNLESS OTHERWISE SPECIFIED ALL DIMENSIONS ARE INCHES [MM]. TOLERANCES: EXCEPT AS NOTED

INCHES		HOLES	
.X	$\pm .10$	ϕ .X	$\pm .10$
.XX	$\pm .020$	ϕ .XX	$\pm .015$
.XXX	$\pm .015$	ϕ .XXX	$\pm .010$

DRAWN	WX	12/18/23
CHECKED	CK	12/18/23
APPROVED		

THIS DRAWING CONTAINS INFORMATION THAT IS PROPRIETARY AND SHOULD NOT BE USED WITHOUT PRIOR WRITTEN PERMISSION FROM ADAM TECH

ADAM TECH

909 Rahway Avenue,
 Union, NJ 07083
 Phone: 908-687-5000
 Fax: 908-687-5710

TITLE		REV.
ENERGY STORAGE CONNECTOR, MALE		C
SIZE	PART NO.	
X	ESM-XXXXA02-XXX	
REF:	S00005C	SHEET 2 OF 3

APPROVED: _____

DATE: _____ TITLE: _____

Rev	AWO #	Description	Date	Appr
SEE SHT 1 OF 3 FOR REVISION				

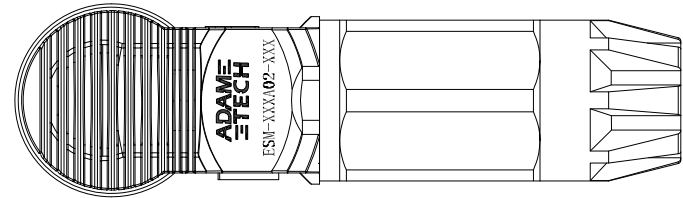
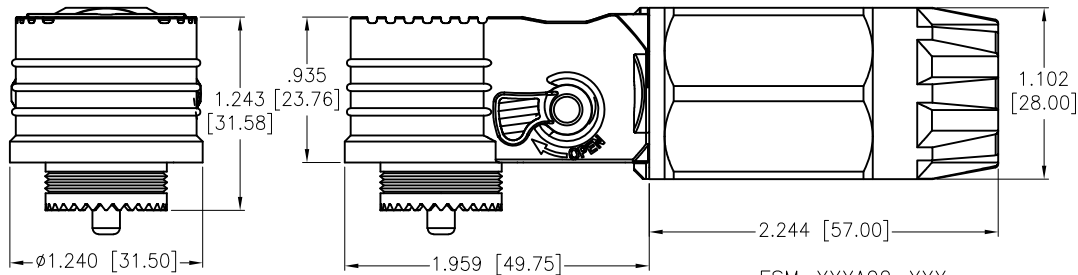

laser marking
 Orange is positive: (+)
 black is negative: (-)

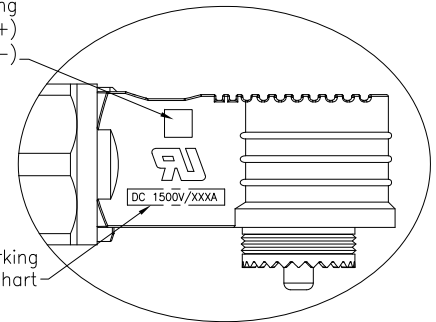

ESM-XXXXA02-XXX
 Universal model: 350A, 300A
 Key Options
 Housing Color:
 O=Orange
 B=Black

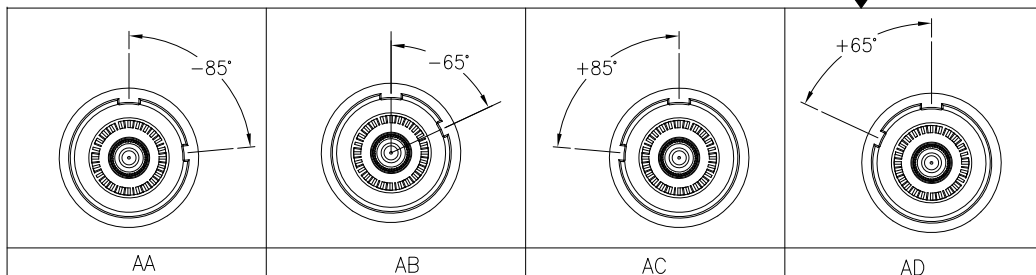

Suitable wire gauge

Specification		Universal model
AWG American wire gauge	Wire standard: 4/0 AWG	350A
	Strand outer diameter: ϕ 14.7 Max	
	O.D (Outside Diameter): ϕ 18.5 Max	
International Wire Gauge	Wire standard: 95mm ²	300A
	Strand outer diameter: ϕ 14.2 Max	
	O.D (Outside Diameter): ϕ 17.6 Max	

SPECIFICATIONS:

Connector:
 Housing: PA66, Glass reinforced, rated UL 94V-0
 Housing color: Orange/Black
 Cap: PA66, Glass reinforced, rated UL 94V-0
 Top: PA66, Glass reinforced, rated UL 94V-0
 Waterproof ring: Silicone
 Contact: Pure Red Copper, Silver plated Surface
 Spring: SUS301
 Electrical:
 Voltage rating: 1500V DC
 Current rating: 300A/350A
 Contact resistance: 0.5 mohms max
 Insulation resistance: 1,000 Mohms min
 Dielectric withstanding voltage: 6,800V DC
 Mechanical:
 Durability: 500 cycles
 Overvoltage Category/Pollution Degree: CATIII/3
 Temperature Rating: -40°C to +125°C
 Environmental:
 Waterproof: IP67 (Mating)
 Lead free, RoHS compliant



UNLESS OTHERWISE SPECIFIED ALL DIMENSIONS ARE INCHES [MM]. TOLERANCES: EXCEPT AS NOTED

INCHES		HOLES	
.X	\pm .10	ϕ .X	\pm .10
.XX	\pm .020	ϕ .XX	\pm .015
.XXX	\pm .015	ϕ .XXX	\pm .010

DRAWN	WX	12/18/23
CHECKED	CK	12/18/23
APPROVED		

THIS DRAWING CONTAINS INFORMATION THAT IS PROPRIETARY AND SHOULD NOT BE USED WITHOUT PRIOR WRITTEN PERMISSION FROM ADAM TECH

ADAM TECH

909 Rahway Avenue,
 Union, NJ 07083
 Phone: 908-687-5000
 Fax: 908-687-5710

TITLE	ENERGY STORAGE CONNECTOR, MALE		
SIZE	PART NO.	ESM-XXXXA02-XXX	REV. C
REF:	S00005C	SCALE: NTS	SHEET 3 OF 3