

APPROVED: \_\_\_\_\_  
 DATE: \_\_\_\_\_ TITLE: \_\_\_\_\_

| Rev | AWO # | Description  | Date    | Appr  |
|-----|-------|--------------|---------|-------|
| -   |       | RELEASED     | 10/7/22 |       |
| A   |       | UPDATE SPEC. | 9/8/23  | LH/RC |

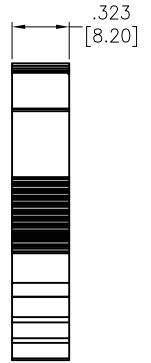
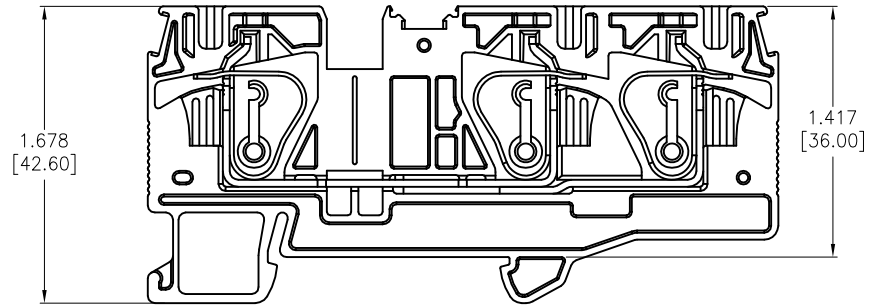
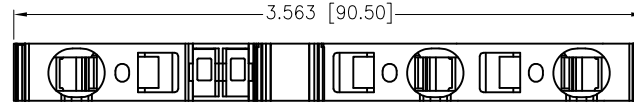
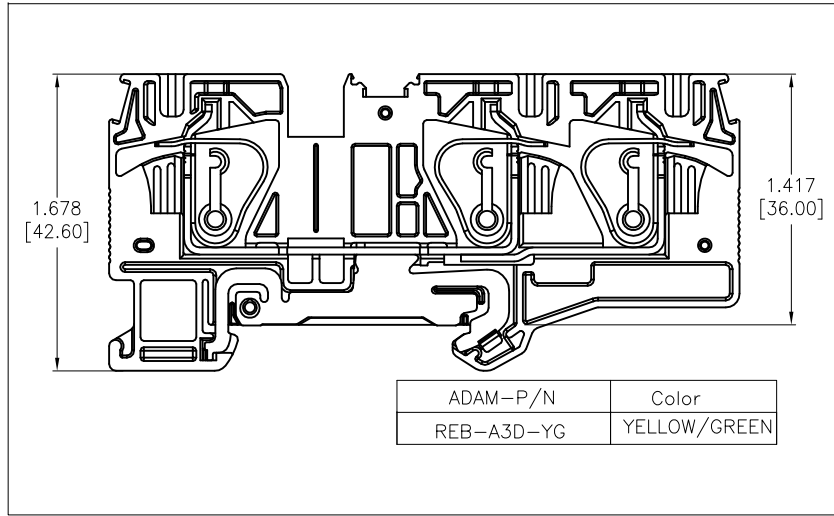

**SPECIFICATIONS:**

**Material:**  
 Insulator: PA66, rated UL 94V-0  
 Insulator color: See chart  
 Contacts: Copper Alloy, Tin Plated  
**Plating:**  
 Electrical:  
 Voltage rating: 600V  
 Current rating: 50A  
 Dielectric withstanding voltage: 2,200 VAC for 1 minute  
**Mechanical:**

**Recommended Wire Size:**  
 Solid: 24-8AWG (0.2-8.3mm<sup>2</sup>)  
 Stranded: 24-10AWG (0.2-5.3mm<sup>2</sup>)  
 Stripping Length: .472" (12mm)  
 Temperature Rating:  
 Operating temperature: -40°C to +105°C

**Environmental:**  
 Lead free, RoHS compliant.

**RECOMMENDED RAIL SIZE**  
 35.0mm X 7.5mm

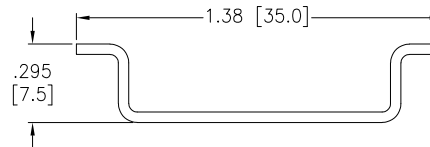

| Color           |
|-----------------|
| OR=Orange       |
| BU=Blue         |
| GY=Gray         |
| YG=Yellow/Green |

| ADAM-P/N   | Color        |
|------------|--------------|
| REB-A3D-BU | BLUE         |
| REB-A3D-GY | GRAY         |
| REB-A3D-YG | YELLOW/GREEN |

UNLESS OTHERWISE SPECIFIED ALL DIMENSIONS ARE INCHES [MM]. TOLERANCES: EXCEPT AS NOTED

| INCHES |       | HOLES |       |
|--------|-------|-------|-------|
| .x     | ±.10  | ∅x    | ±.10  |
| .xx    | ±.020 | ∅xx   | ±.015 |
| .xxx   | ±.015 | ∅xxx  | ±.010 |

**ADAM TECH** 909 Rahway Avenue,  
 Union, NJ 07083  
 Phone: 908-687-5000  
 Fax: 908-687-5710

|          |    |         |
|----------|----|---------|
| DRAWN    | WX | 10/7/22 |
| CHECKED  | RC | 10/7/22 |
| APPROVED |    |         |

| TITLE   |            |      |
|---|------------|------|
| DIN RAIL TERMINAL BLOCKS, GUS, 3 HOLE, 6.0 FLEXIBLE |            |      |
| SIZE  | PART NO.   | REV. |
| X   | REB-A3D-XX | A    |

THIS DRAWING CONTAINS INFORMATION THAT IS PROPRIETARY AND SHOULD NOT BE USED WITHOUT PRIOR WRITTEN PERMISSION FROM ADAM TECH

|      |         |        |     |       |        |
|------|---------|--------|-----|-------|--------|
| REF: | S00067C | SCALE: | NTS | SHEET | 1 OF 1 |
|------|---------|--------|-----|-------|--------|