

6

5

4

3

2

1

APPROVED: _____

DATE: _____ TITLE: _____

| Rev | AWO # | Description | Date | Appr |
|-----|-------|--------------|---------|-------|
| - | | RELEASED | 10/7/22 | |
| A | | UPDATE SPEC. | 9/8/23 | LH/RC |

D

D

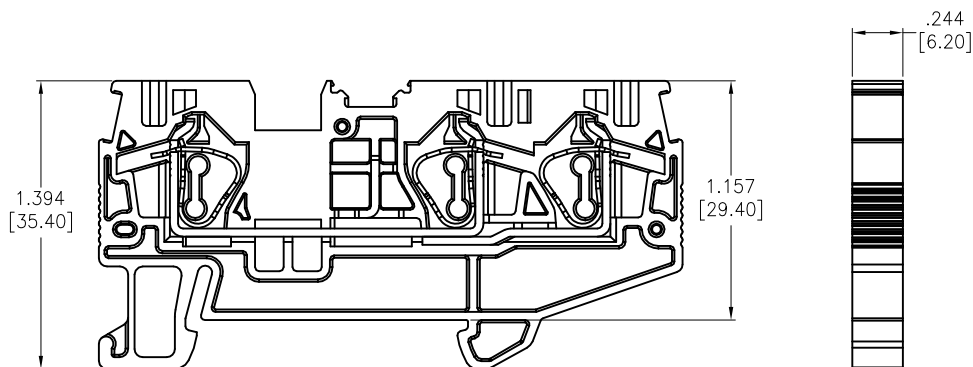
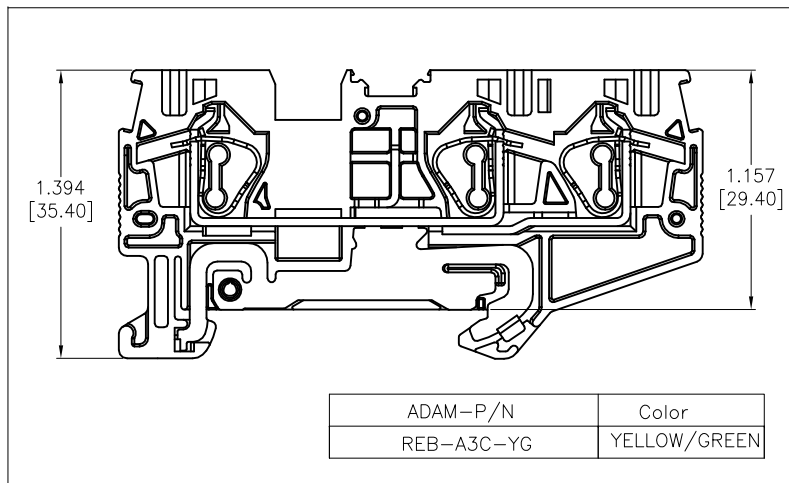
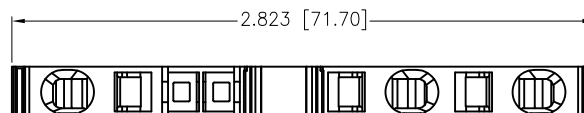

C

C

B

B

SPECIFICATIONS:

Material:
 Insulator: PA66, rated UL 94V-0
 Insulator color: See chart
 Contacts: Copper Alloy, Tin Plated
Electrical:
 Voltage rating: 600V
 Current rating: 30A
 Dielectric withstanding voltage: 2,200 VAC for 1 minute
Mechanical:
 Recommended Wire Size:
 Solid: 24-10AWG (0.2-5.3mm²)
 Stranded: 24-12AWG (0.2-3.3mm²)
 Stripping Length: .315"~.394" (8-10mm)
 Temperature Rating:
 Operating temperature: -40°C to +105°C
Environmental:
 Lead free, RoHS compliant.

A

A

RECOMMENDED RAIL SIZE
35.0mm X 7.5mm

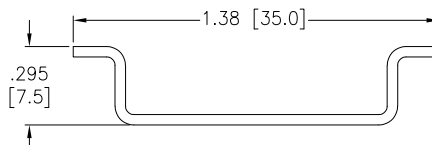

| | | |
|---|--------------|-----------------|
| REB-A 3 C -XX | | Color |
| Solid/Stranded: | | OR=Orange |
| Solid: 24-10 Awg (0.2-5.3mm ²) | | BU=Blue |
| Stranded: 24-12 Awg (0.2-3.3mm ²) | | GY=Gray |
| | | YG=Yellow/Green |
| ADAM-P/N | Color | |
| REB-A3C-BU | BLUE | |
| REB-A3C-GY | GRAY | |
| REB-A3C-YG | YELLOW/GREEN | |

UNLESS OTHERWISE SPECIFIED ALL DIMENSIONS ARE INCHES [MM]. TOLERANCES: EXCEPT AS NOTED

| INCHES | | HOLES | |
|--------|--------|-------|--------|
| .X | ± .10 | ∅X | ± .10 |
| .XX | ± .020 | ∅XX | ± .015 |
| .XXX | ± .015 | ∅XXX | ± .010 |



909 Rahway Avenue,
Union, NJ 07083
Phone: 908-687-5000
Fax: 908-687-5710

| | | |
|----------|----|---------|
| DRAWN | WX | 10/7/22 |
| CHECKED | RC | 10/7/22 |
| APPROVED | | |

| | | | | | |
|-------|------------|--------|--|--------------|--|
| TITLE | | | DIN RAIL TERMINAL BLOCKS, GUS, 3HOLE, 4.0 FLEXIBLE | | |
| SIZE | PART NO. | REV. | | | |
| X | REB-A3C-XX | A | | | |
| REF: | S00067C | SCALE: | NTS | SHEET 1 OF 1 | |

6

5

4

3

2

1