

APPROVED: \_\_\_\_\_  
 DATE: \_\_\_\_\_ TITLE: \_\_\_\_\_

Rev	AWO #	Description	Date	Appr
-		RELEASED	4/1/14	
A		REVISED SPEC.	1/8/15	AY/RT
B		REVISED SPEC. & PACKING.	8/17/17	AY/DH
C		ADDED BOARDLOCKS DIM.	5/23/19	AY/KC

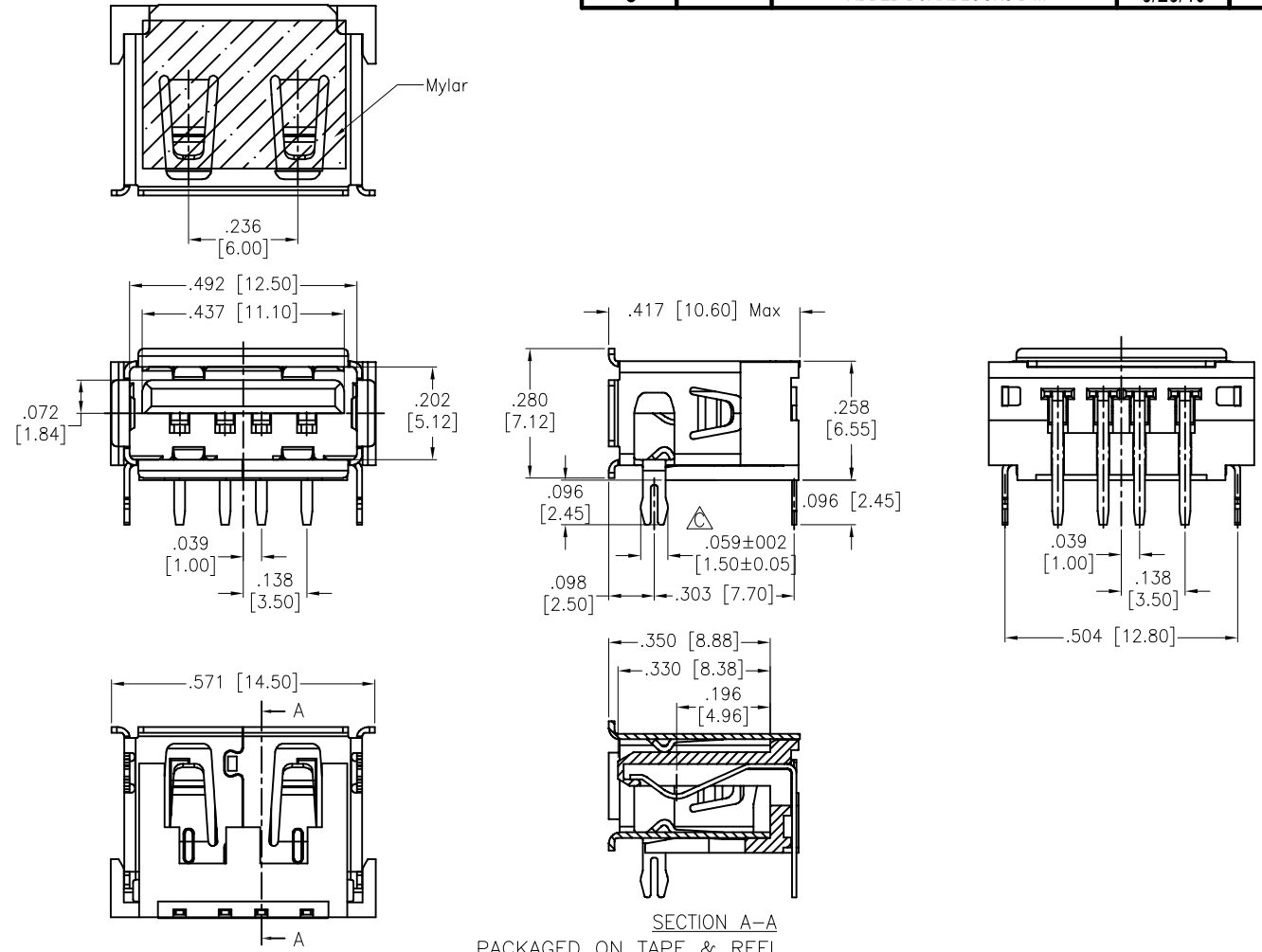

RECOMMENDED PCB LAYOUT

**SPECIFICATIONS:**

**Material:**  
 Insulator: Hi-Temp Thermoplastic, rated UL 94V-0  
 Insulator color: Black  
 Contacts: Copper Alloy  
 Shell: Copper Alloy  
**Plating:**  
 Gold over Nickel underplate on contact area,  
 Tin over Nickel underplate on PCB tails.  
**Electrical:**  
 Current rating: 2.1A.  
 Voltage rating: 30V AC/DC.  
 Contact resistance: 30 mohms max.  
 Insulation resistance: 1000 Mohms min  
 Dielectric withstanding voltage: 500 VAC for 1 minute  
**Mechanical:**  
 Insertion force: 35 Newtons max  
 Extraction force: 10 Newtons min  
 Temperature Rating:  
 -55°C to +85°C  
**Environmental:**  
 Lead free, RoHS compliant.



SECTION A-A  
 PACKAGED ON TAPE & REEL

UNLESS OTHERWISE SPECIFIED ALL DIMENSIONS ARE INCHES [MM] TOLERANCES: EXCEPT AS NOTED		
INCHES		HOLES
.X ± .10	Ø.X ± .10	
.XX ± .020	Ø.XX ± .015	
.XXX ± .015	Ø.XXX ± .010	
APPROVALS		DATE
DRAWN	HR	4/1/14
CHECKED	LL	4/1/14
APPROVED		

**ADAM TECH INTERCONNECTS** 909 Rahway Avenue,  
 Union, NJ 07083  
 Phone: 908-687-5000  
 Fax: 908-687-5710

TITLE: UNIVERSAL SERIAL BUS, TYPE A, PCB  
 RIGHT ANGLE, BOARD LOCKS, W/ MYLAR

SIZE X	PART NO. USB-A-S-RA-BL-CS1-HT-KT-T/R	REV. C
REF: S00217T	SCALE: NTS	SHEET 1 OF 2

6

5

4

3

2

1

APPROVED: \_\_\_\_\_  
 DATE: \_\_\_\_\_ TITLE: \_\_\_\_\_

Rev	AWO #	Description	Date	Appr
SEE SHT 1 OF 2 FOR REVISION				

D

D

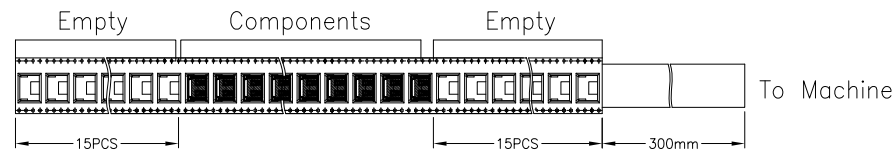
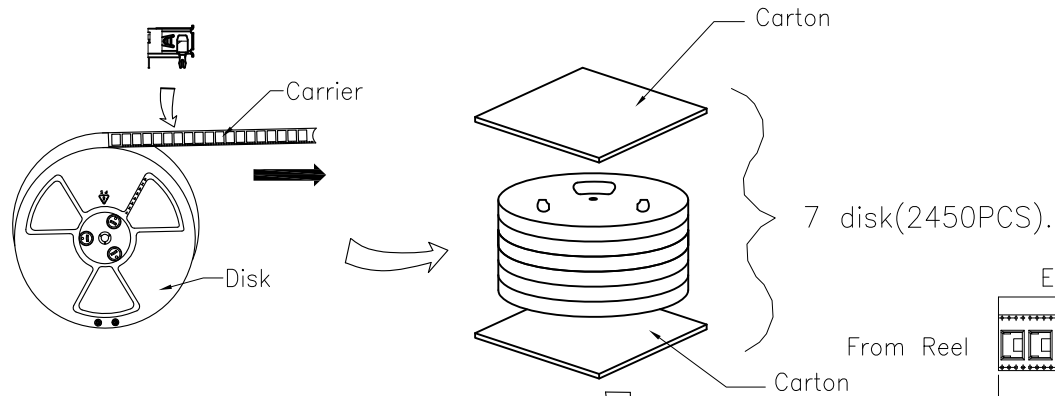

USER DIRECTION FO FEED

C

C

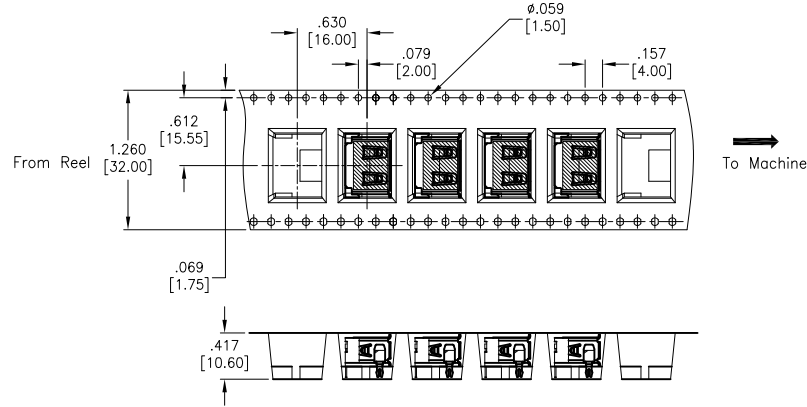
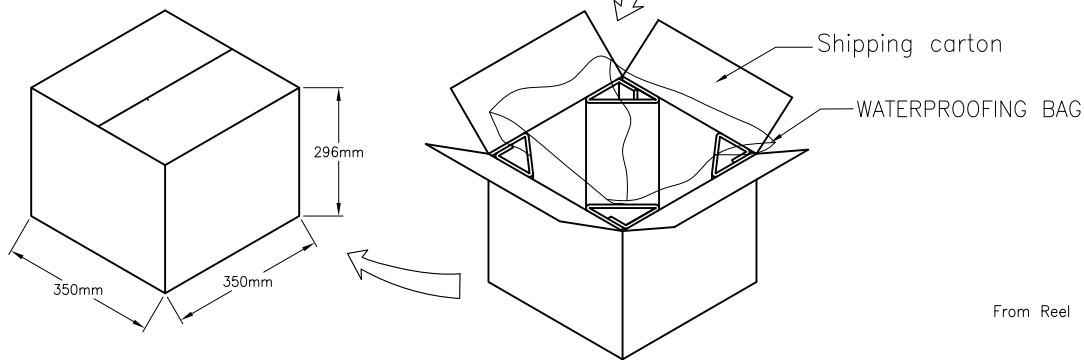

**NOTES:**

**Material:**

- 1 Carrier: Clear Anti-Static Polystyrene.
- 2 Shipping carton: corrugated fiberboard
- 3 Waterproofing bag: PE

**Dimension:**

- 1 Carrier: Thickness: 0.5 ± 0.05mm.
- 2 Disk: Diameter ø330mm.

**Quantity:**

- 1 Primary packing: 350 PCS/Disk.
- 2 Secondary packing: 7 Disk(2450PCS).

A

A

UNLESS OTHERWISE SPECIFIED ALL DIMENSIONS ARE INCHES [MM] TOLERANCES: EXCEPT AS NOTED INCHES HOLES .X ± .10 Ø.X ± .10 .XX ± .020 Ø.XX ± .015 .XXX ± .015 Ø.XXX ± .010		<b>ADAM TECH</b> INTERCONNECTS		909 Rahway Avenue, Union, NJ 07083 Phone: 908-687-5000 Fax: 908-687-5710	
				TITLE: UNIVERSAL SERIAL BUS, TYPE A, PCB RIGHT ANGLE, BOARD LOCKS, W/ MYLAR	
APPROVALS	DATE	SIZE	PART NO.	REV.	
DRAWN	HR	X	USB-A-S-RA-BL-CS1-HT-KT-T/R	C	
CHECKED	LL				
APPROVED					
REF: S00217T		SCALE: NTS		SHEET 2 OF 2	

6

5

4

3

2

1