

6

5

4

3

2

1

APPROVED: _____
DATE: _____ TITLE: _____

Rev	AWO #	Description	Date	Appr
-		RELEASED	10/19/16	
A		REDRAWN AND UPDATED	10/2/23	

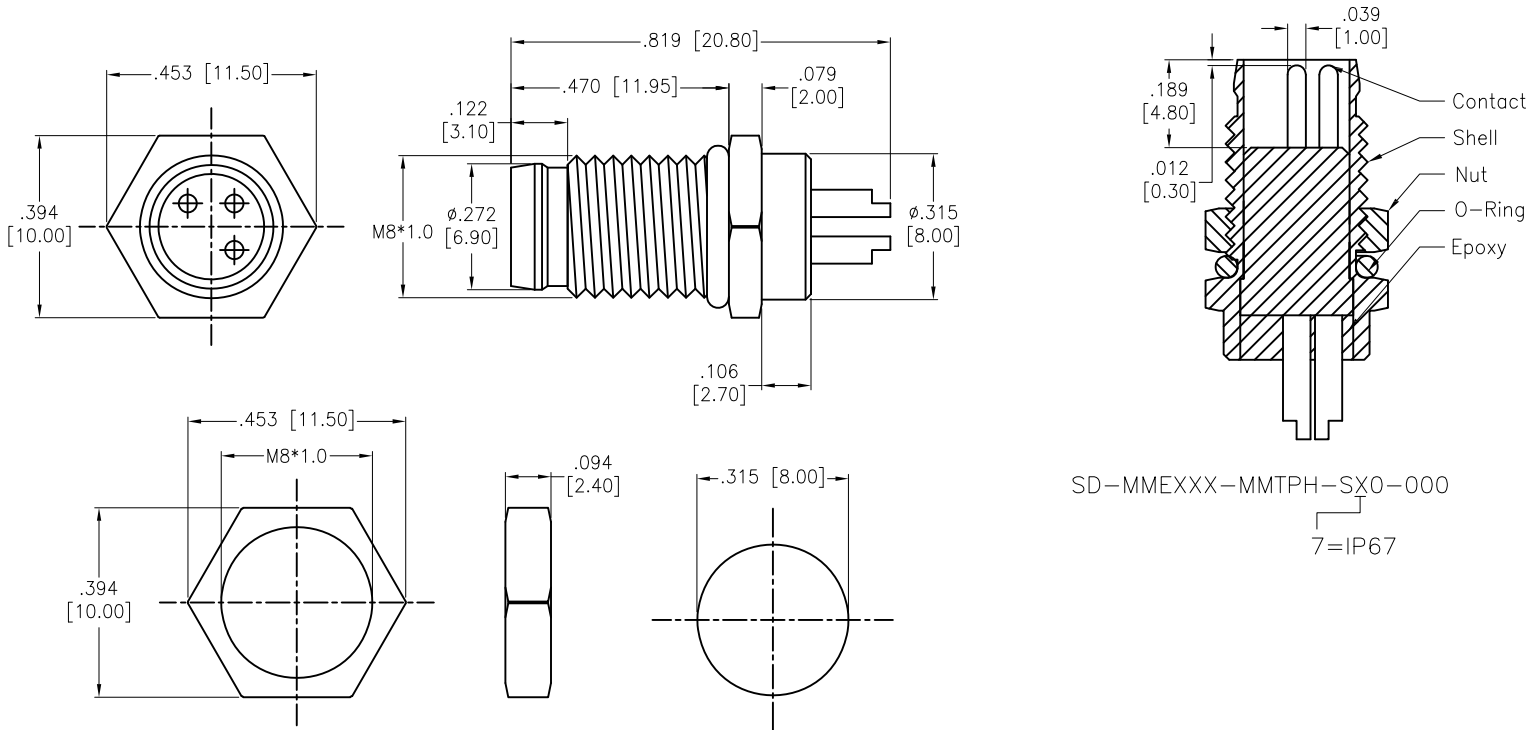

SD-MMEXXX-MMTPH-SX0-000
7=IP67

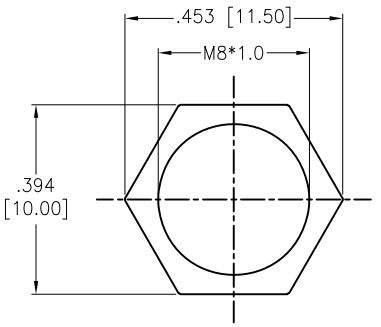

Nut

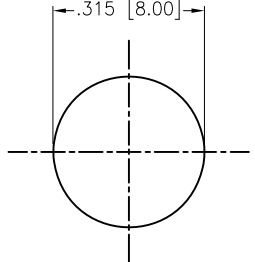
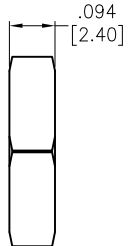

RECOMMENDED PANEL CUT

SD-MMEXXX-MMTPH-SX0-000

HOUSING	PBT	BLACK
NUT	BRASS, NICKEL PLATED	
O-RING	NBR	BLACK
CONTACT	BRASS, 10u" GOLD PLATED	
SHELL	BRASS, NICKEL PLATED	
PART NAME	DESCRIPTION	COLOR

SPECIFICATIONS:
 Electrical:
Voltage rating: 60V
Current rating: 4A
 Temperature Rating:
Operating temperature: -20°C to +85°C
 Environmental:
Waterproof: IP67
Lead free, RoHS compliant.

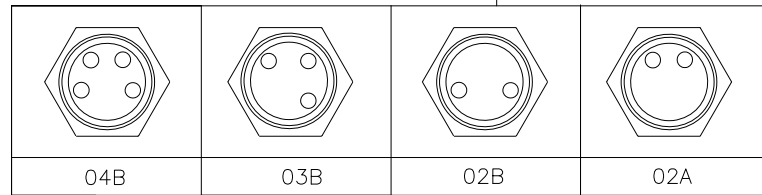

UNLESS OTHERWISE SPECIFIED ALL DIMENSIONS ARE INCHES [MM]. TOLERANCES: EXCEPT AS NOTED

INCHES		HOLES	
.X	± .10	Ø.X	± .10
.XX	± .020	Ø.XX	± .015
.XXX	± .015	Ø.XXX	± .010

DRAWN	HR	10/19/16
CHECKED	CK	10/19/16
APPROVED		

THIS DRAWING CONTAINS INFORMATION THAT IS PROPRIETARY AND SHOULD NOT BE USED WITHOUT PRIOR WRITTEN PERMISSION FROM ADAM TECH

ADAM TECH

909 Rahway Avenue,
 Union, NJ 07083
 Phone: 908-687-5000
 Fax: 908-687-5710

TITLE: **WATERPROOF CONNECTOR, MALE, M8
 SCREW MOUNT, SOLDER TYPE, 2 THRU 4 PIN**

SIZE X	PART NO. SD-MMEXXX-MMTPH-SX0-000	REV. A
REF: S00298T	SCALE: NTS	SHEET 1 OF 2

6

5

4

3

2

1

6

5

4

3

2

1

APPROVED: _____
DATE: _____ TITLE: _____

Rev	AWO #	Description	Date	Appr
SEE SHT 1 OF 2 FOR REVISION				

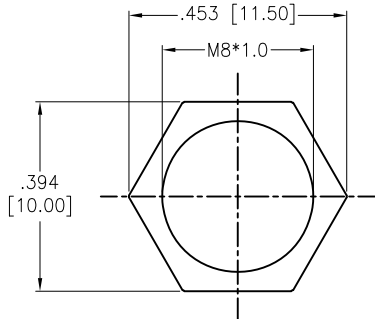
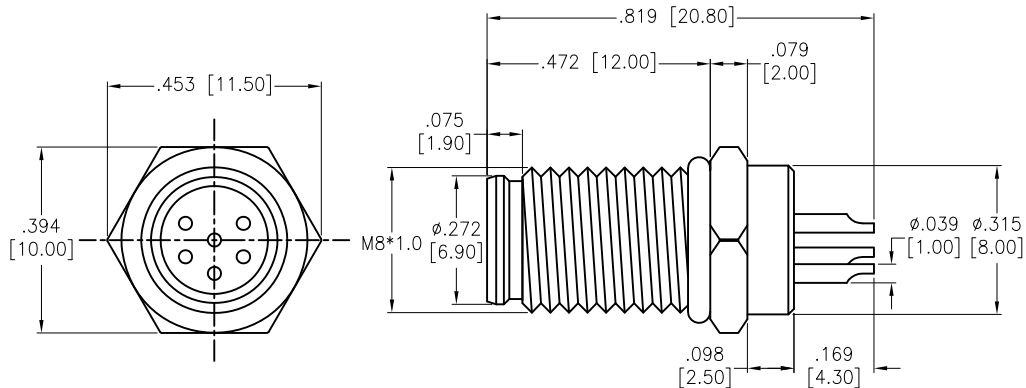

Nut

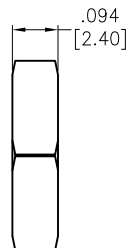

RECOMMENDED PANEL CUT

SD-MMEXXX-MMTPH-SX0-000
7=IP67

SD-MMEXXX-MMTPH-SX0-000

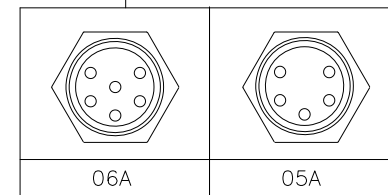

HOUSING	PBT	BLACK
NUT	BRASS, NICKEL PLATED	
O-RING	NBR	BLACK
CONTACT	BRASS, 10u" GOLD PLATED	
SHELL	BRASS, NICKEL PLATED	
PART NAME	DESCRIPTION	COLOR

SPECIFICATIONS:

Electrical:

Voltage rating: 60V

Current rating: 1A

Temperature Rating:

Operating temperature: -40°C to +105°C

Environmental:

Waterproof: IP67

Lead free, RoHS compliant.



UNLESS OTHERWISE SPECIFIED ALL DIMENSIONS ARE INCHES [MM]. TOLERANCES: EXCEPT AS NOTED

INCHES	HOLES
.X ± .10	ØX ± .10
.XX ± .020	ØXX ± .015
.XXX ± .015	ØXXX ± .010

DRAWN	HR	10/19/16
CHECKED	CK	10/19/16
APPROVED		

THIS DRAWING CONTAINS INFORMATION THAT IS PROPRIETARY AND SHOULD NOT BE USED WITHOUT PRIOR WRITTEN PERMISSION FROM ADAM TECH

ADAM TECH 909 Rahway Avenue, Union, NJ 07083
Phone: 908-687-5000 Fax: 908-687-5710

TITLE WATERPROOF CONNECTOR, MALE, M8
SCREW MOUNT, SOLDER TYPE, 5 AND 6 PIN

SIZE X	PART NO. SD-MMEXXX-MMTPH-SX0-000	REV. A
REF: S00298T	SCALE: NTS	SHEET 2 OF 2

6

5

4

3

2

1